



**STRING  
FURNITURE**

2026





NEW String® System in Dark oak

# Content

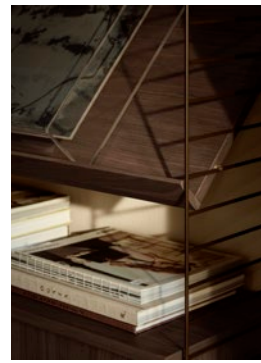

String® 06



Pira 40



Museum 52

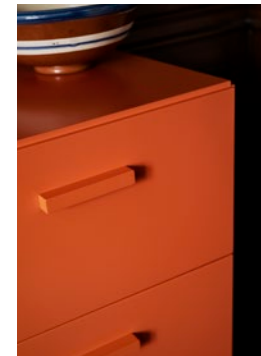

Relief 64

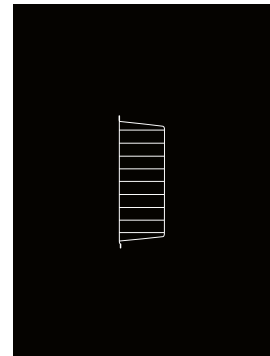

Details 78

String® 06-39





Floor panels | H200 D30 | White  
Metal shelves high | W78 D30 | White

Rod | W78 | White  
Shoe shelves | W78 | White



Wall panels | H75 D30 | White  
Cabinets with sliding doors | W78 | White

Metal shelves high | W78 | White



NEW | Floor panels | H200 D30 | Dark brown  
NEW | Cabinets with sliding doors | W78 | Dark oak



NEW | Magazine shelves | W78 | Dark oak



J-hooks | White  
Hanger racks | D30 | White

Cabinets with sliding doors | W78 D30 | Walnut

Metal shelf high | W58 D30 | White  
Metal shelves high | W78 D30 | White





String® Pocket | W60 D15 H50 | Tegnérgrön



2 x String® Pocket | W60 D15 H50 | Walnut & Black



Chest of drawers | W78 | Ash  
Cabinet with sliding doors | W78 | Ash



Organisers | Beige  
Bowl shelf felt | W78 | Light grey





Rod | W53 | White

Wall panels | H75 D30 | White  
Metal shelves high | W58 D30 | White



NEW | Work desk | W58 | Oak



Cabinet with flip door | W58 | Oak  
Metal shelves high | W58 D30 | White

Wall panels | H50 D20 | Plex  
Shelves | W58 D20 | Black stained ash

Wall panels | H50 D30 | Plex  
Chest of drawers | W78 | Black stained ash



Wall panels | H50 D20 | Plex



Vertical hooks | Stainless steel  
Back panel | W58 H36 | Galvanized

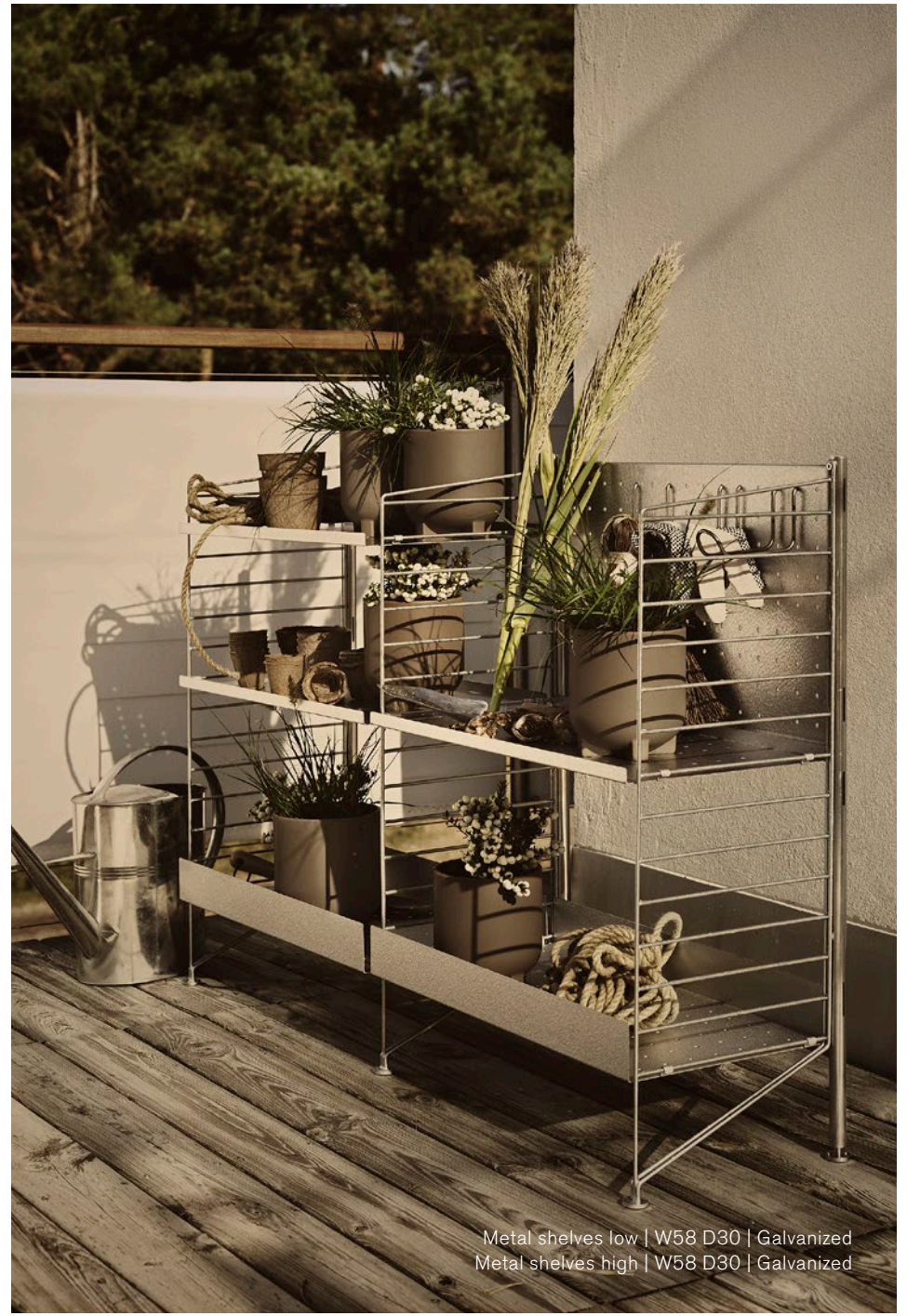

Metal shelves low | W58 D30 | Galvanized  
Metal shelves high | W58 D30 | Galvanized



Floor panels | H115 D30 | Galvanized  
Metal shelves high | W58 D30 | Galvanized

Pira 40-51





Floor-to-ceiling mounted | W160 D31 | White  
NEW | Display cabinet with four doors | W90 | White oak | Clear glass



NEW | Display cabinet with four doors | W90 | Walnut | Clear glass



NEW | Display cabinet with glass back | W90 | Walnut | Fluted glass



Cabinets | W90 | W70 | Walnut  
Floor-to-ceiling mounted | H250 | Black grey



Magazine shelf | W32,5 | Walnut & black grey

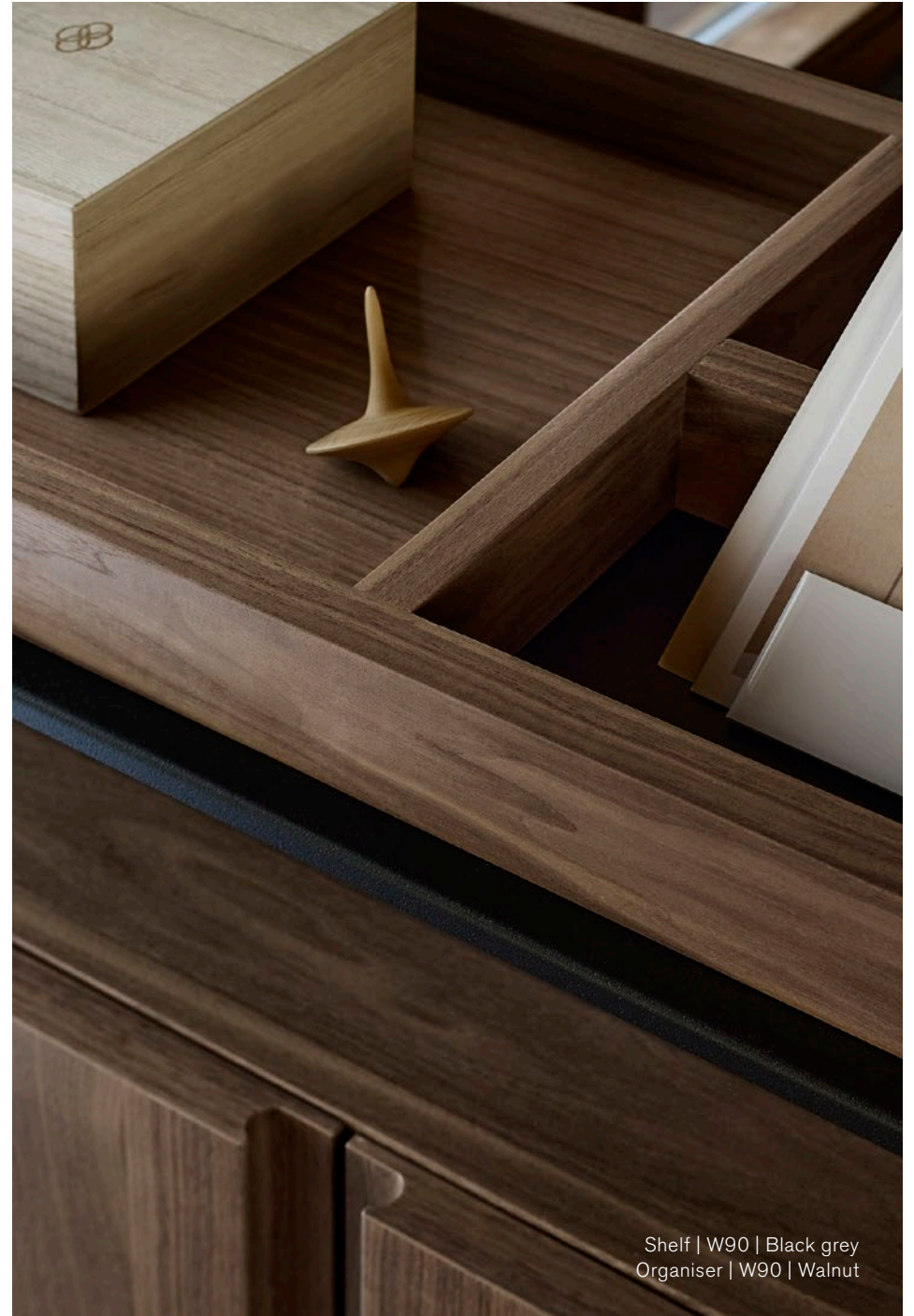

Shelf | W90 | Black grey  
Organiser | W90 | Walnut



Cabinets | W70 | White oak  
Wall mounted | H220 | White

Museum 52-63





NM&.045 console shelf | Dark brown



Sidetable | Orange



NEW | Pedestal | Green



NEW | Trolley | Orange



NEW | Pedestal | Beige



Sidetable | Green



NEW | Trolley | Beige  
Candle holder | Dark brown

Relief 64–77





2 x Chest of drawers, wide | W82 D41 H92 | Grey



Chest of drawers, wide | W82 D41 H92 | Grey



Chest of drawers, low | W123 D41 H46.5 | Orange





Hook rail, large | W123 | Orange



Hook rail, small | W41 | Ash



Chest of drawers, low | W123 D41 H46.5 | Ash



Chest of drawers, wide | W82 D41 H92 | Beige

Hook rail, large | W123 | Beige

# Details

String® 80–95

Pira 96–101

Museum 102–105

Relief 106–107

The original blue print from 1949

# String® System

DESIGN BY NISSE & KAJSA STRINNING IN 1949.

String® has earned its place in design history thanks to its elegant simplicity and ingenious construction. Designed by Nisse and Kajsa Strinning in 1949, the String® shelf won its first design prize in the same year. Based on three simple elements – the shelf, the wall panel and the metal fitting – it can be combined in an infinite number of configurations and is endlessly reinvented as it passes from one generation to the next.

Although a trained architect, Nisse was actually more interested in designing smaller everyday objects that could have a big impact on people's lives. Already as a child, he had designed and built his own bookcase. As an adult, he had all knowledge and practical experience to recreate that bookcase, making it open, affordable, space-saving, and expandable to any size.

But without Strinning's wife Kajsa – also an architect – the String® shelf might never have past the prototype stage. Unlike her husband, Kajsa had the artistic talent to refine Nisse's raw industrial designs. Together, they formed a winning team.

In the years that followed, the String® shelf appeared in interior design magazines and at trade fairs, its popularity spread to the rest of Europe, the United States and South America. Finally, in 1954 String® was awarded the gold medal at the Milan Triennale.

Today, String® comprises of an entire system, with new colours, materials, and accessories that have been added over time. Some of them blueprint ideas from Nisse's archives; others created by contemporary Swedish designers. Its basic construction – the shelf, the wall panel and the metal fittings – always remain identical to the 1949 original. String® continues to grow and is currently sold in 45 countries. Manufacturing still takes place in the same factory in Sweden just as in 1949; with the wall panels being made just a few kilometres away from where the shelves are produced. Although Nisse passed away in 2006 and Kajsa in 2017, their designs are still very much alive and thriving.

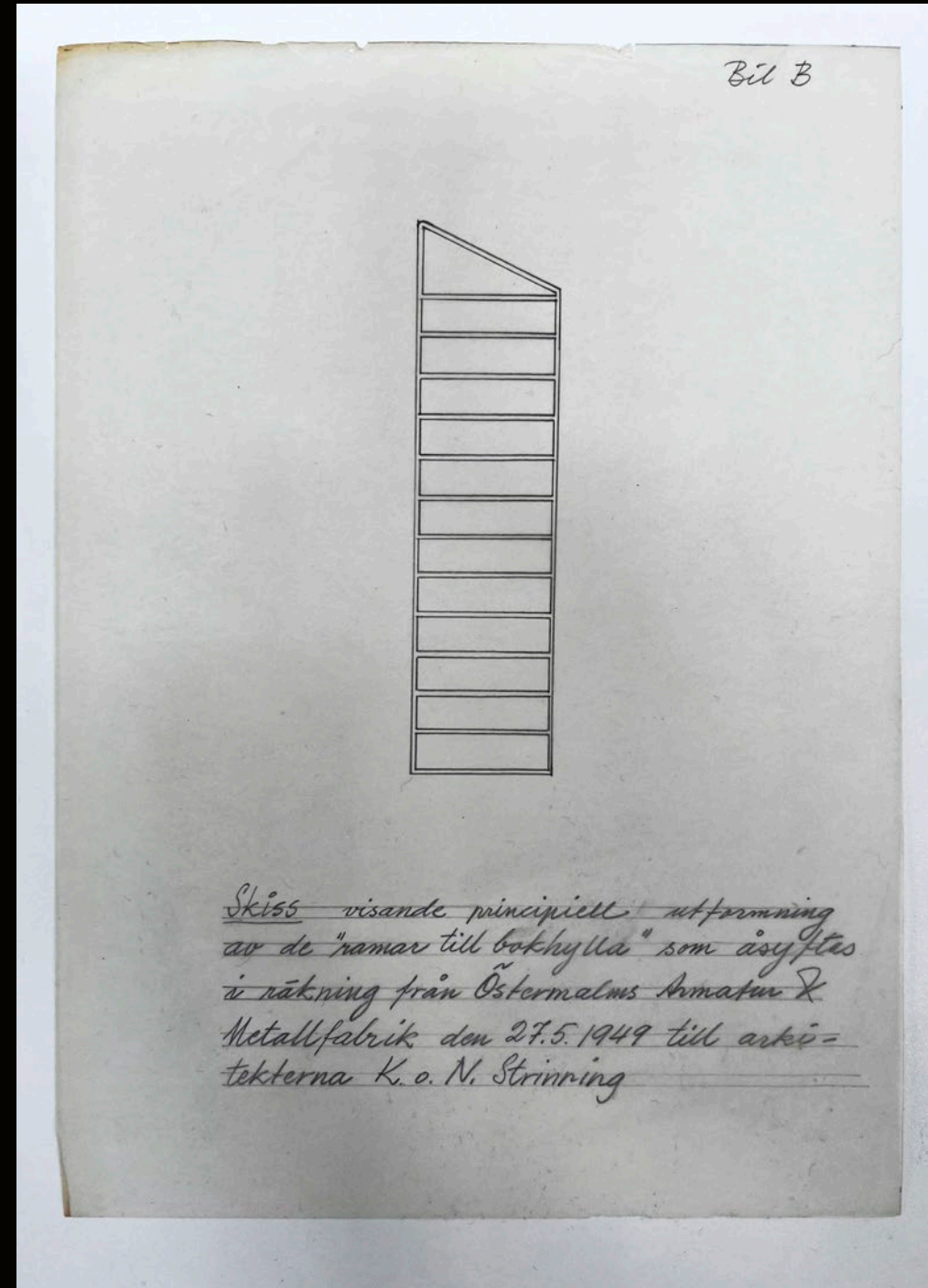



KAJSA STRINNING. ARCHITECT

NISSE STRINNING. ARCHITECT AND INVENTOR  
His final design was String® Pocket, in 2005

## STRING® SYSTEM

The String® System is a series of components featuring the classic wire panels that offer almost unlimited combinations. you can choose among a wide range of colours and materials to build your own, personal shelving system, based on standard widths of 60 cm and 80 cm and two depths, 20 cm and 30 cm.

Start planning your String® combination here: [www.stringfurniture.com/string-planner](http://www.stringfurniture.com/string-planner)

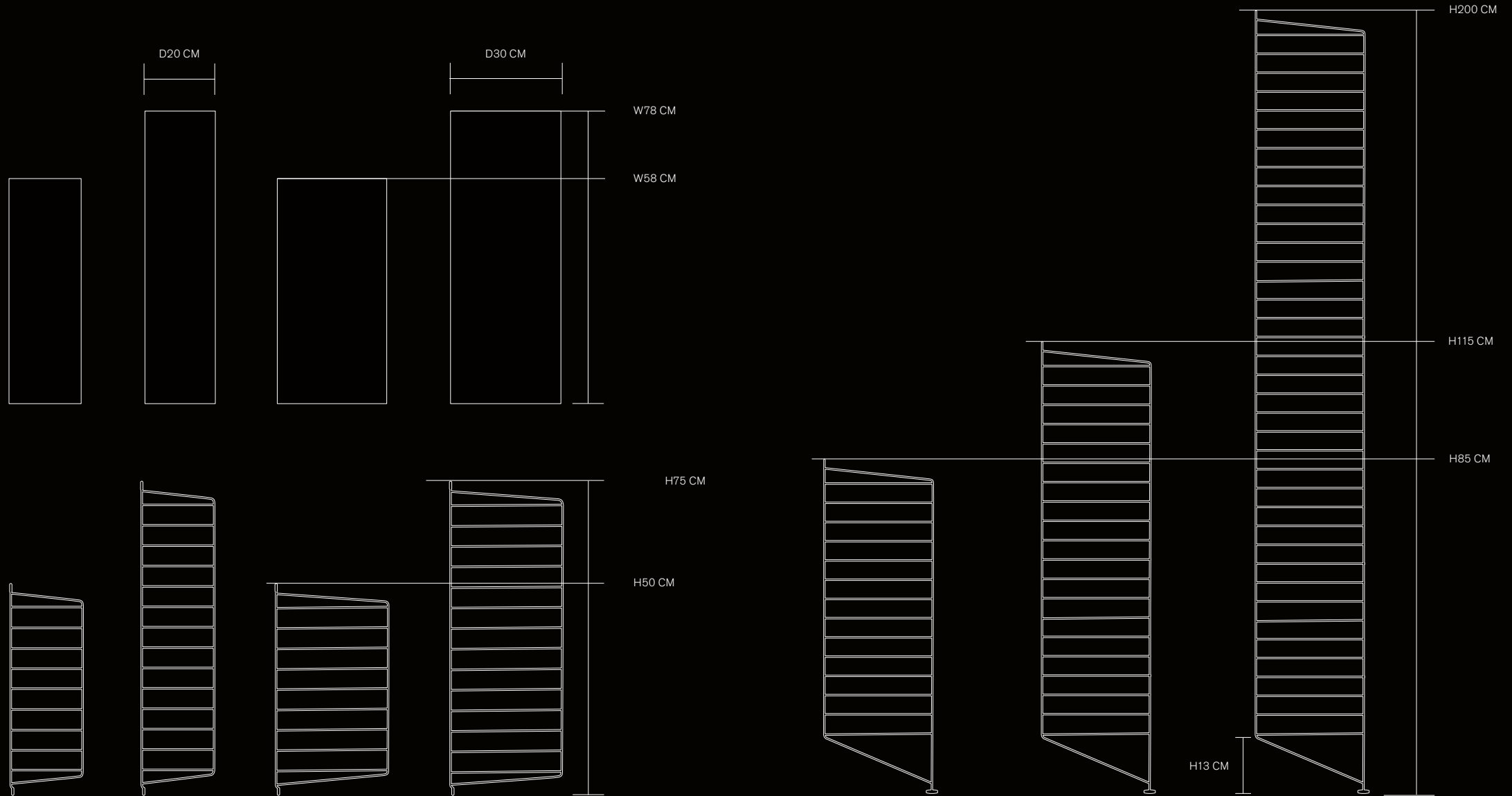

STRING® SYSTEM

Wood

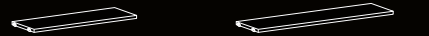
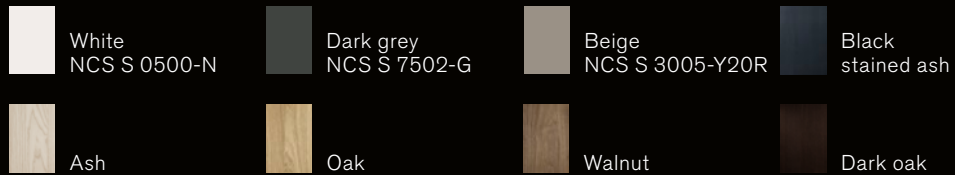

**SHELVES**  
W58-78 CM D20 CM

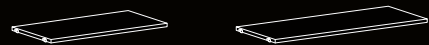

**SHELVES**  
W58-78 CM D30 CM



**SHELVES METAL HIGH**  
W58-78 CM D30 CM H7 CM

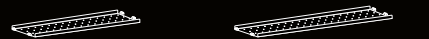

**SHELVES METAL LOW**  
W58-78 CM D20 CM H2 CM



**SHELVES METAL LOW**  
W58-78 CM D30 CM H2 CM



**MAGAZINE SHELVES**  
W58-78 CM D30 CM



**BOWL SHELF ABS PLASTIC**  
W78 CM D30 CM INSIDE D8,5 CM

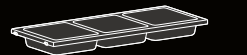
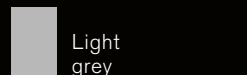

**BOWL SHELF FELT**  
W78 CM D30 CM INSIDE D5 CM

Metal

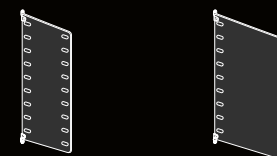
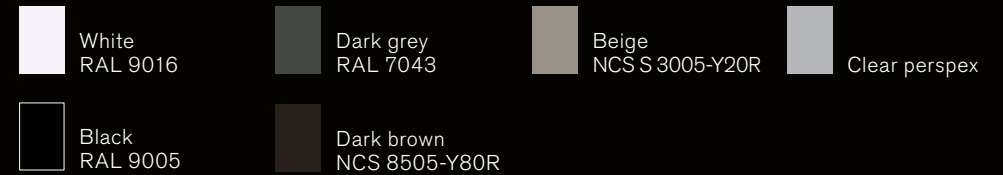

**PLEX WALL PANELS**  
H50 CM D20-30 CM

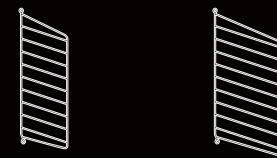

**WALL PANELS**  
H50 CM D20-30 CM

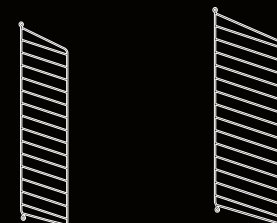

**WALL PANELS**  
H75 CM D20-30 CM

Plex



**MAGAZINE SHELF METAL - not with plex panels**  
W78 CM D30 CM

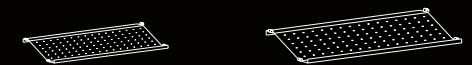

**SHOE SHELVES - not with plex panels**  
W58-78 CM D30 CM

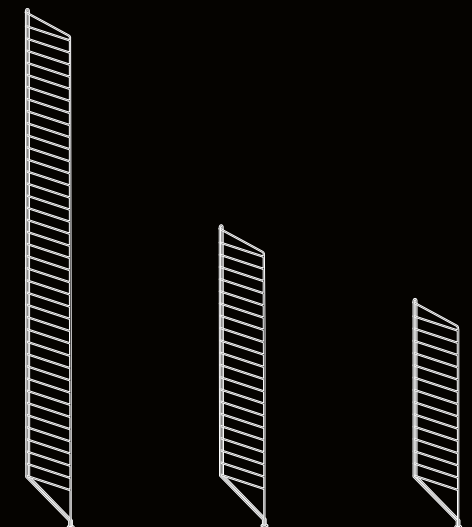

**FLOOR PANELS**  
H200-115-85 D30 CM

To avoid flex we recommend max. 15 kg evenly spread load on 78 cm wide shelves and 25 kg on 58 cm wide shelves.

NCS – Natural Colour System®© property of and used on licence from Scandinavian Colour Institute AB, Stockholm 2006.

STRING® SYSTEM

Wood

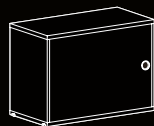
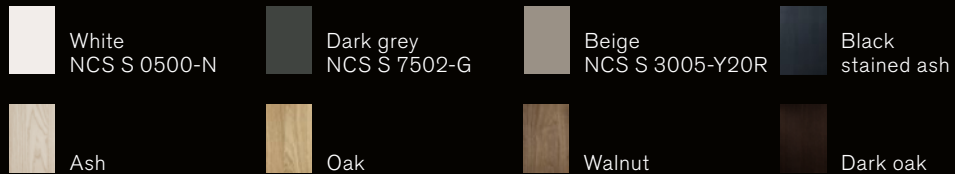

**CABINET WITH SWING DOOR**  
W58 CM D30 CM H42 CM

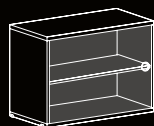

**CABINET WITH SWING GLASS DOOR**  
W58 CM D30 CM H42 CM

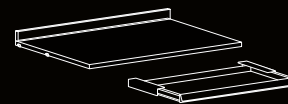

**WORK DESK** W78 CM D58 CM  
**DESK DRAWER - black or white** W61 CM D30 CM



**WORK DESK**  
W58 CM D58 CM



**MEDIA SHELF**  
W58 CM D47 CM

Media Shelf

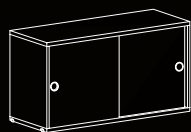
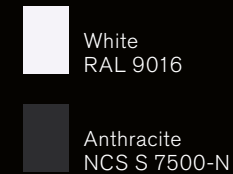

**CABINET WITH SLIDING DOORS**  
W78 CM D20-30 CM H37-42 CM

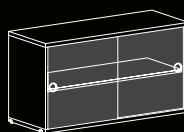
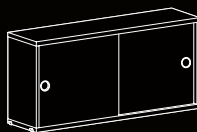

**CABINET WITH SLIDING GLASS DOORS**  
W78 CM D30 CM H42 CM



**CHEST OF DRAWERS**  
W58-78 CM D30 CM H42 CM



Cabinet with sliding mirror doors

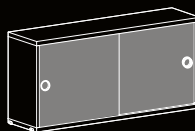

**CABINET WITH SLIDING MIRROR DOORS**  
W78 CM D20 CM H37 CM

Folding table

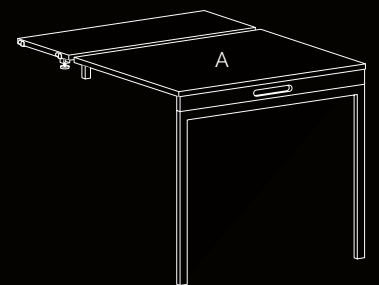

**FOLDING TABLE - only with floor panels**  
W78 CM D96 CM H71 CM

STRING® SYSTEM

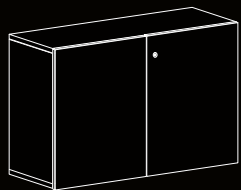
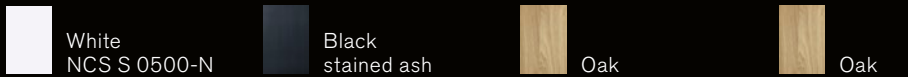

**CABINET WITH LOCK**  
W78 CM D32.2 CM H52 CM

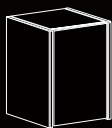
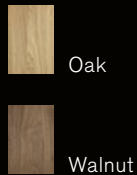

**TINY CABINET**  
W28 CM D30 CM H38 CM

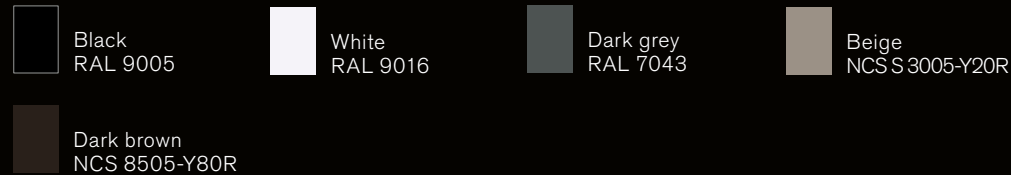

**HANGER RACK**  
W13.5 CM D30 CM H3 CM

STRING® SYSTEM ACCESSORIES

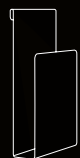
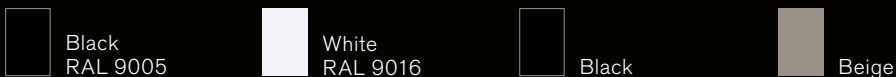

**MAGAZINE HOLDER**  
D17 CM H27 CM

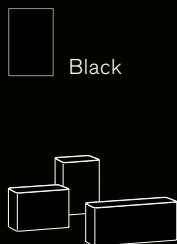

**ORGANISER**  
W9-20 CM D7-8 H8-12 CM



**HANGER RACK**  
W13.5 CM D20 CM H3 CM

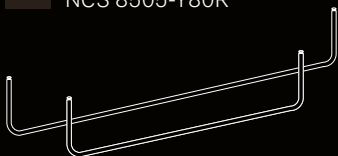
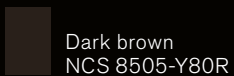

**ROD**  
W53-74 CM D1 CM H8 CM



**HOOK**  
D4 CM H8 CM

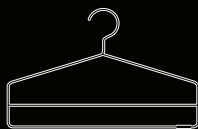

**COAT-HANGER**  
W41 CM H26 CM



**BOTTLE TRAY CORK**  
W19 CM D30 CM H2 CM



Galvanized



**WALL PANELS 50**  
D30 CM H50 CM



**FLOOR PANEL**  
D38 CM H85 CM



**UPRIGHT**  
H87 CM

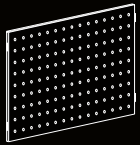

**BACK PANEL**  
W58 CM H36 CM

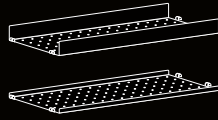

**SHELVES**  
W58 CM D30 CM H2-7 CM



Stainless steel

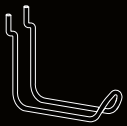

**VERTICAL DOUBLE HOOK**  
W4 CM D11.5 CM H10 CM



**VERTICAL HOOK**  
D3.5 CM H10 CM



**S HOOK**  
W5 CM D1 CM H5 CM



**J HOOK**  
D4 CM H8 CM

## STRING® POCKET

String® Pocket is the small light and handy little one. It comes in a variety of colours and materials. It's sold as a complete unit of two panels and three shelves. You can combine them in a number of ways, for example, with two units you can build up to three sections with two shelves each.



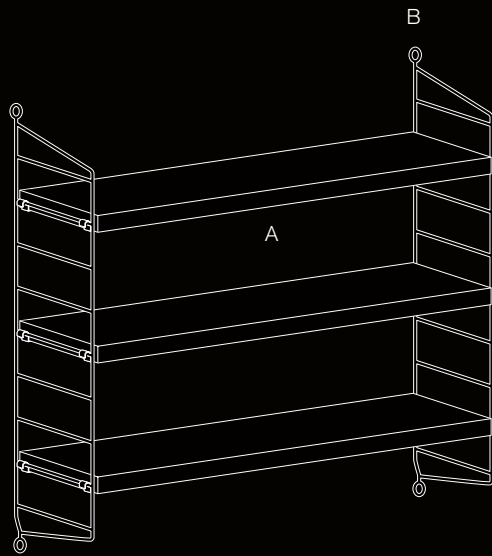



 A White NCS S 0500-N	 A Dark grey NCS S 7502-G	 A Sage RAL 7009	 A Nybrolå NCS S 8010-R90B
 B White RAL 9016	 B Dark grey RAL 7043	 B Sage RAL 7009	 B Nybrolå RAL 5011
 A Black stained ash	 A Walnut	 A Oak	 A Ash
 B Black RAL 9005	 B Black RAL 9005	 B White RAL 9016	 B White RAL 9016
 A Tegnérgrön RAL 6004	 A Dark oak		
 B Tegnérgrön RAL 6004	 B Dark brown NCS 8505-Y80R		



**STRING® POCKET**  
W60 CM D15 CM H50 CM

## STRING® POCKET METAL

String® Pocket metal adds new possibilities. The metal shelves combine thinness and strength with the classic look. Also, the shelves are perforated and ideal for adding accessories like hooks, rods and more. Of course String® Pocket metal can be combined and expanded in many different ways.

 A White RAL 9016	 A Oxtorgsröd RAL 3011	 A Sergelgrå NCS 7010-B10G
 B White RAL 9016	 B Oxtorgsröd RAL 3011	 B Sergelgrå NCS 7010-B10G

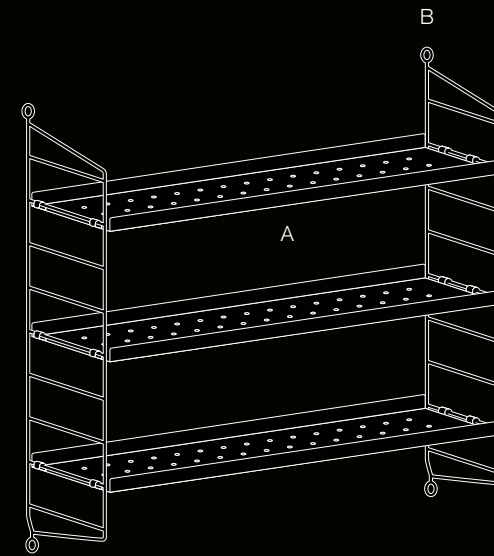

**STRING® POCKET METAL**  
W60 CM D15 CM H50 CM

Drawing by Björn Dahlström of updated Pira

# Pira

DESIGN BY OLLE PIRA 1954/ANNA VON SCHEWEN AND BJÖRN DAHLSTRÖM 2023.

The Pira shelf is as contradictory as the man who conceived it; Olle Pira was a traditional master cabinet maker. He crafted cherry, maple and matured oak with age-old skills. Yet he still won a place at the renowned Konstfack school of art, craft and design in Stockholm, the birthplace of concepts ahead of their times. He also became the first Swede to win a gold medal at the Triennale in Milan in 1952.

In 1954 he designed an innovative construction that adapted to various heights, yet bore eye-stretching loads, with a design that exuded a confident calm. But technology and materials, our habits and needs have evolved since 1954. Simultaneously, our ceilings heights have risen and spaces have opened up.

Designers Anna von Schewen and Björn Dahlström took on the classic and carefully crafted an updated version, whilst staying true to the original design. The updated Pira is a spun, metallic work of art that becomes a centre-piece wherever it stands. Even far from the centre of a space. It is the sum of many parts, an interlocked series of joints, poles, flats and triangles. Complex and sophisticated indeed, but capable of creating calm and wellbeing wherever it lives. The metalwork reassures, yet its walnut and white oak cabinets pacify. A technical feat, yet a beautiful one.

"Pira meets the needs of today, yet retain the brilliance of the 1950's classic. Its relevance salutes the past." Björn Dahlström

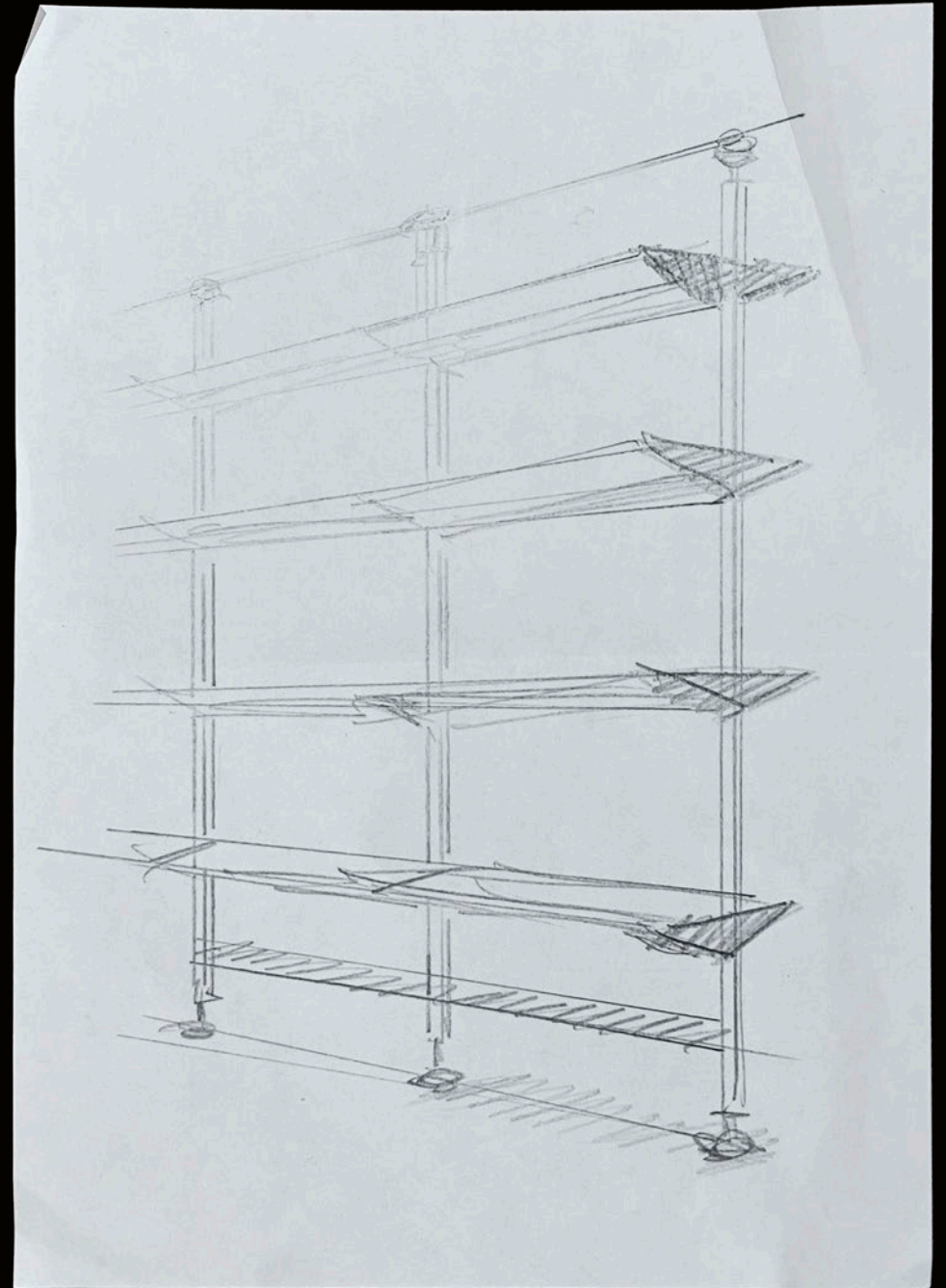

# PIRA

Pira is a metallic work of art that creates a centre-piece wherever it stands. Each shelf carries up to 50 kg, thanks to its sheet-steel construction with an integral ridge. Or, 350 kg in each section.

Start planning your Pira here: [www.stringfurniture.com/pira-planner](http://www.stringfurniture.com/pira-planner)

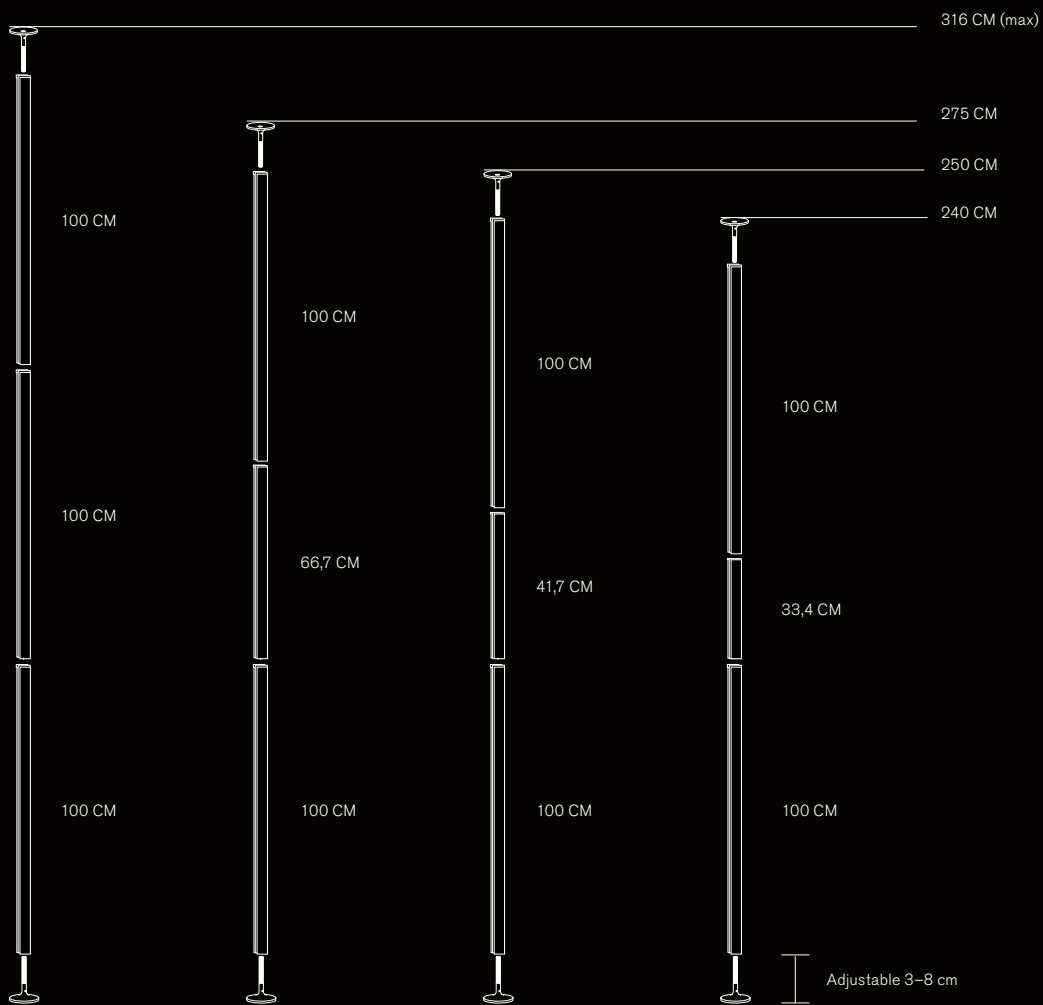

For wall & wall-to-ceiling mounted  
Distance from wall: 36 CM

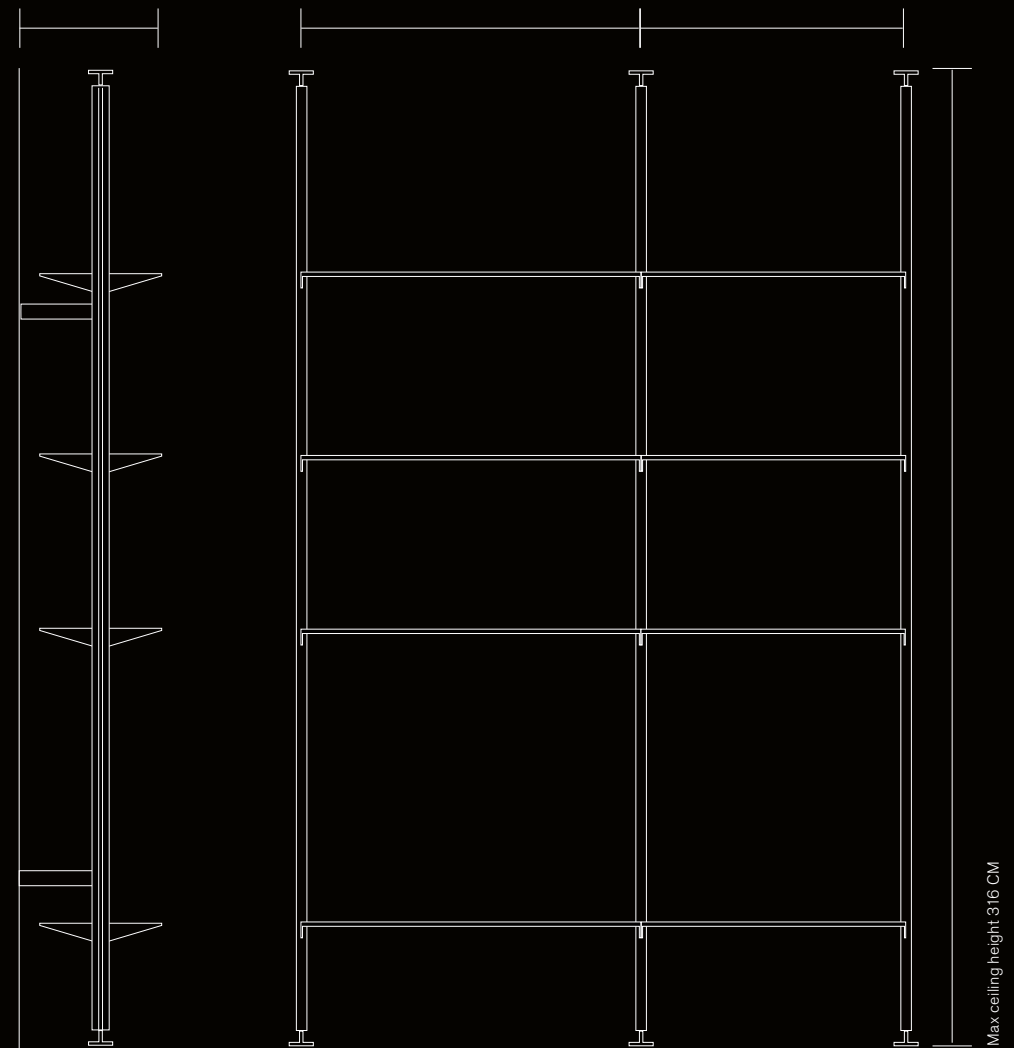

PIRA

Pira is the sum of many parts: poles in eleven sizes connected by joints create a seamless and bespoke height. Add shelves in steel, cabinets, organisers and bookends in walnut or white oak.

Wood

Metal

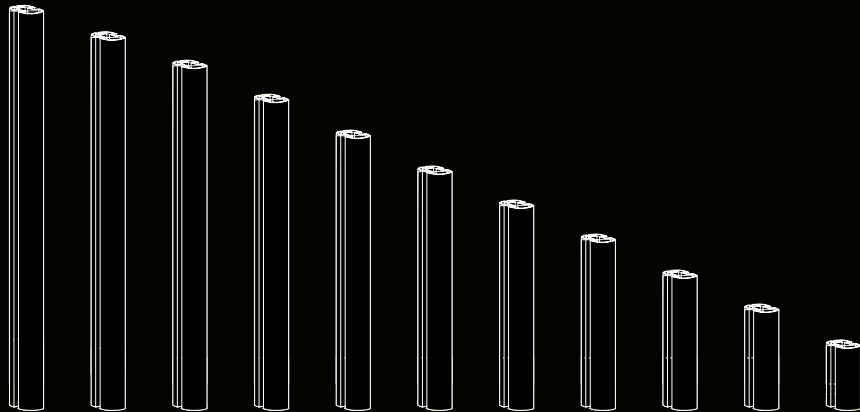

**POLE**  
H100-16,7 CM



**SHELF**  
W70-90 CM

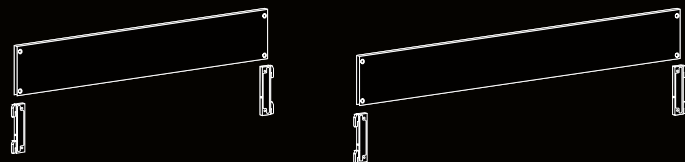

**SUPPORT BEAM**  
W70-90 CM



**BOOKEND**

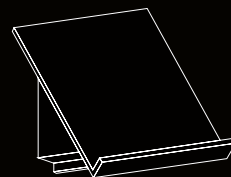

**MAGAZINE SHELF**  
W32,5 CM

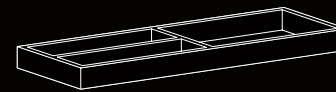

**ORGANISER**  
W70-90 CM

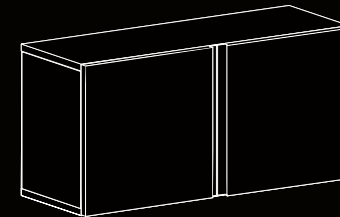

**CABINET**  
W70-90 CM

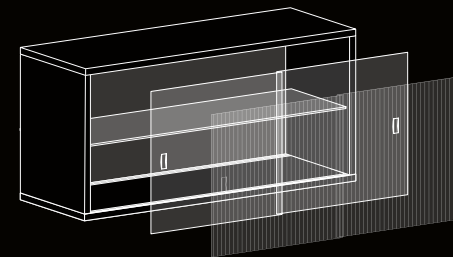
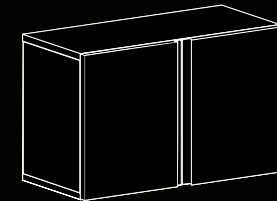

**CABINET WITH GLASS BACK**  
**CLEAR OR FLUTED GLASS**  
W70-90 CM

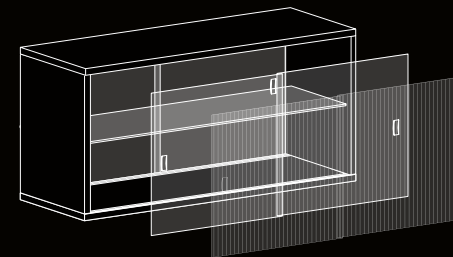
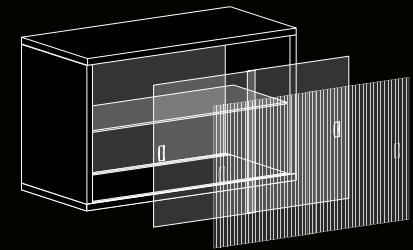

**CABINET WITH FOUR DOORS**  
**CLEAR OR FLUTED GLASS**  
W70-90 CM

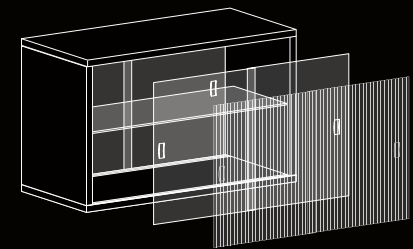

# Museum and Relief

DESIGN BY TAF STUDIO.

Gabriella Lenke and Mattias Ståhlbom are free thinkers, they continually challenge traditional definitions. Together they established the design and architecture studio TAF in 2002. Asked to describe the work of TAF Studio, they speak of "spatial design" as their approach, where the spatial thinking and the products cross-fertilise each other.

The Museum NM&.045 shelf is a good example of this, originally designed by TAF Studio for Sweden's National Museum of Fine Arts in Stockholm in 2018. The shelf had to support everything from precious vases to heavy figurines and sculptures. "We wanted to create the feeling that the wall reaches out toward you, like the palm of a hand presenting the art", says Gabriella. The success of the NM&.045 inspired TAF Studio to create the free-standing, height-adjustable Museum Sidetable. This year, we launch two new products in the same uncompromising spirit: the Pedestal and the Trolley.

Relief designed in 2024 is another example, a storage system for clothes that adapt to any space, and appeal to all tastes. The solid chest of drawers come in five different colours, heights and widths, flexible and engineered to lock together as one unit. And the hook rails have as many colours and lengths as the chests of drawers. Any colour, any length, works any way.



## MUSEUM

Museum, with its distinctly functional design and solid build, was made to carry and present precious art objects in gallery spaces. Now also in homes and workspaces.

NM&.045 also available in:

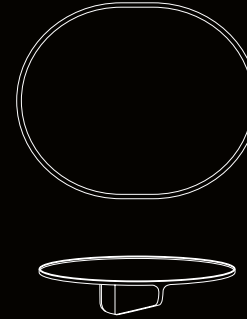
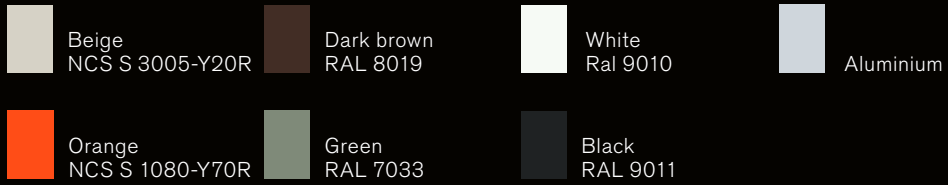

**NM&.045**  
W28 CM D24 CM H8 CM

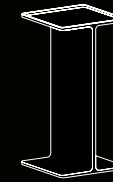

**PEDESTAL**  
W15 CM D15 CM H30 CM

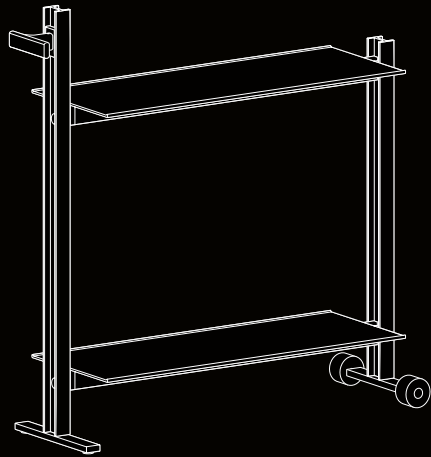

**TROLLEY**  
W74,5 CM D24 CM H77,5 CM

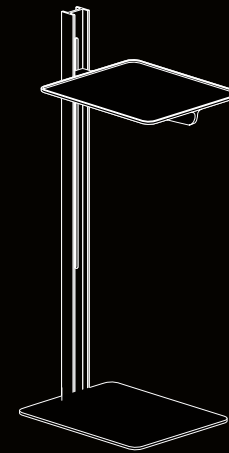

**SIDETABLE**  
W24 CM D30 CM H76 CM

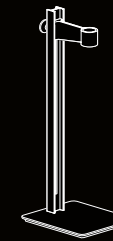

**CANDLE HOLDER**  
W13 CM D15 CM H40 CM

## RELIEF

Relief is actually a system: the chest of drawers can be connected, or freestanding - the hook rails complement the chest of drawers, in both size and colour.

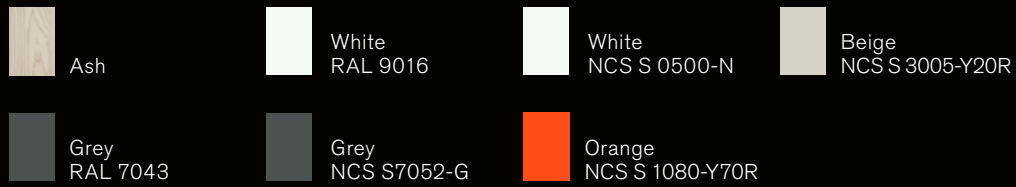

**HOOK RAIL, LARGE**  
W123 CM D5 CM H5 CM



**HOOK RAIL, MEDIUM**  
W82 CM D5 CM H5 CM



**HOOK RAIL, SMALL**  
W41 CM D5 CM H5 CM

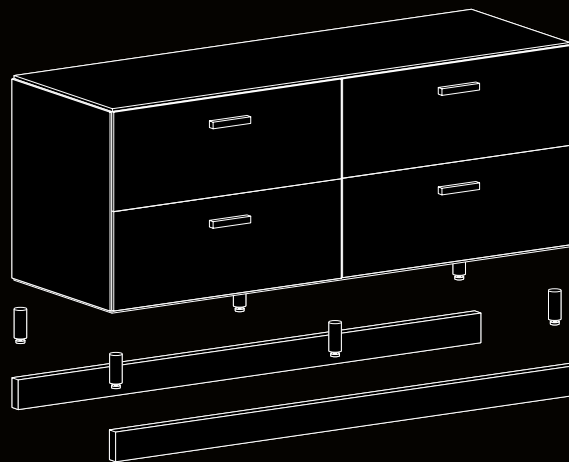

**CHEST OF DRAWERS, LOW**  
W123 CM D41 CM H 46.5 CM



**CHEST OF DRAWERS, WIDE**  
W82 CM D41 CM H 92 CM



**CHEST OF DRAWERS, TALL**  
W41 CM D41 CM H115 CM



String Furniture  
Limhamnsvägen 110  
216 13 Limhamn, Sweden  
[stringfurniture.com](http://stringfurniture.com)

